



MAGNA1

VALID FROM MODEL C

Further product
documentation



net.grundfos.com/qr/i/99209952

be
think
innovate

GRUNDFOS 



MAGNA1



MAGNA1 D

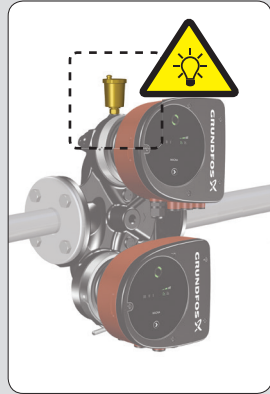
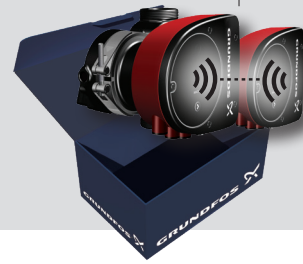



MAGNA1 F



MAGNA1 D F

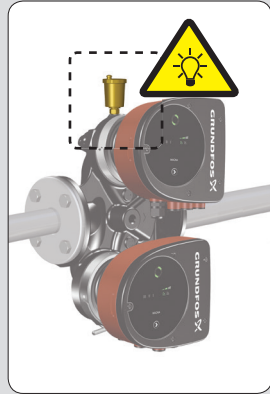
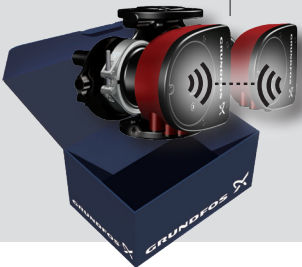



Max. 95 % RH
IPX4D



Min./Max.
-10 °C – +110 °C



PN 6:6 bar / 0.6 MPa
PN 10:10 bar / 1.0 MPa
PN 16:16 bar / 1.6 MPa



Min./Max.
0 °C – +40 °C



< 39 dB(A)



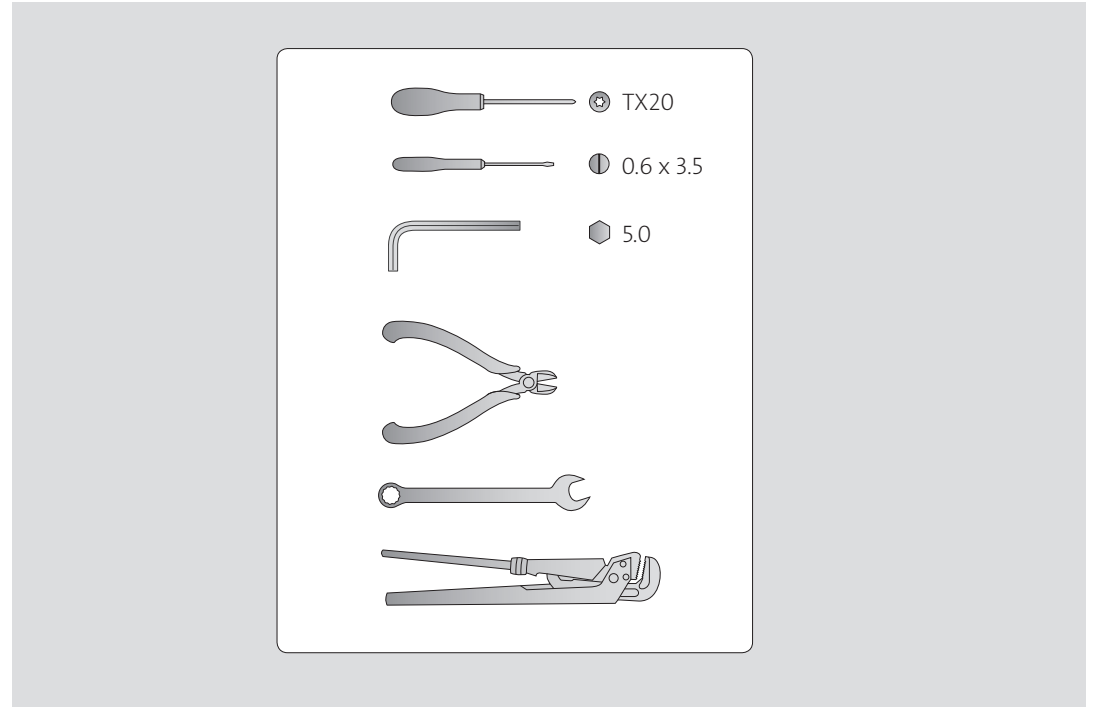
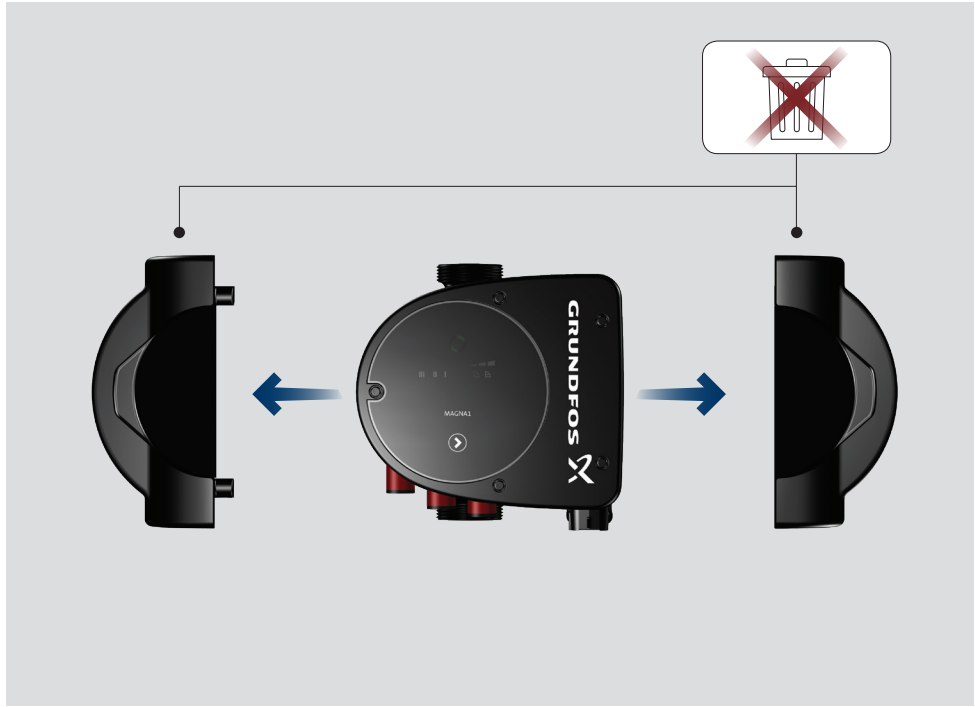

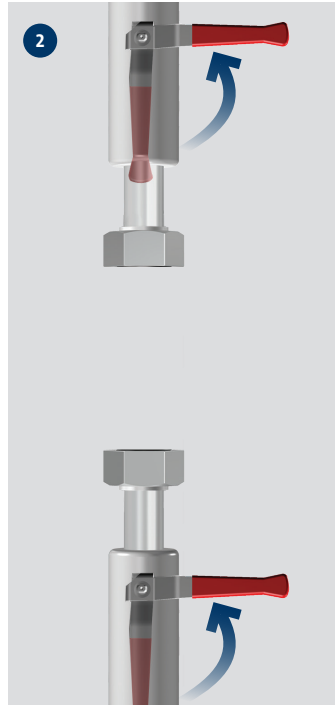

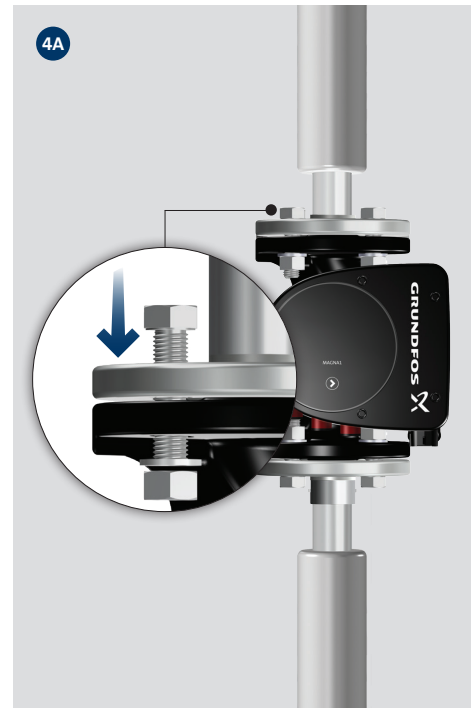

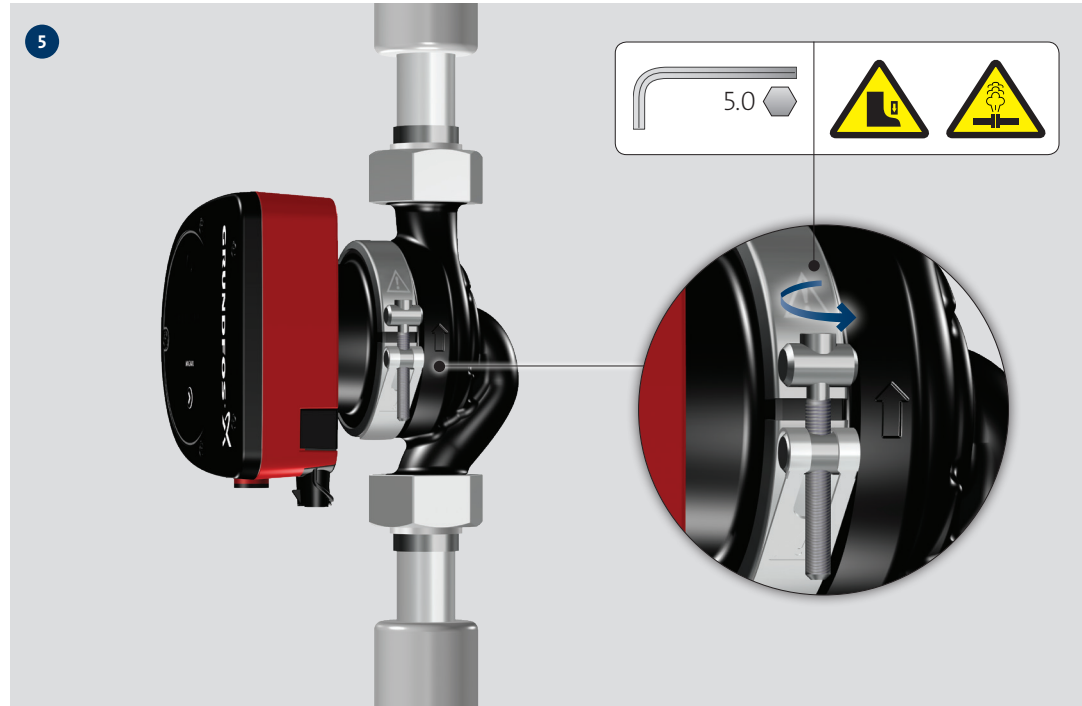
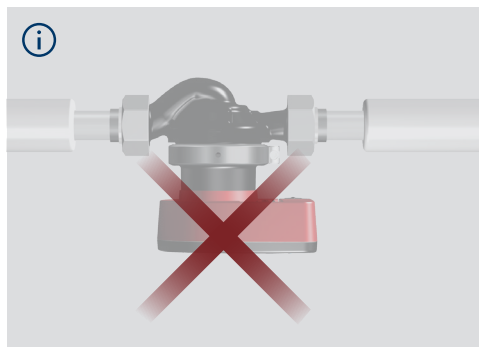
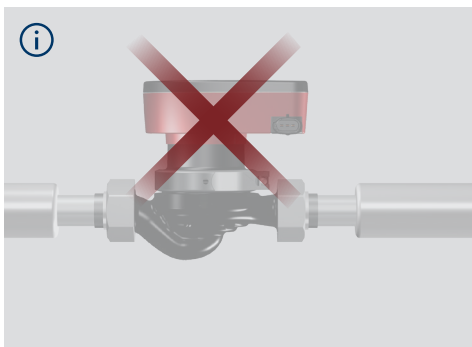
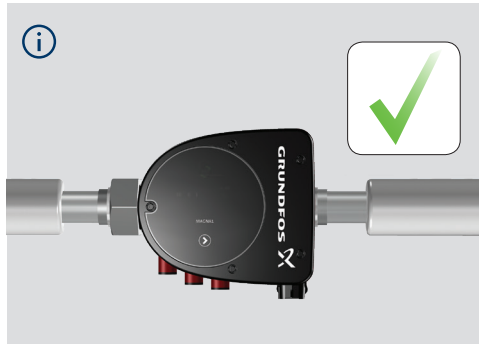

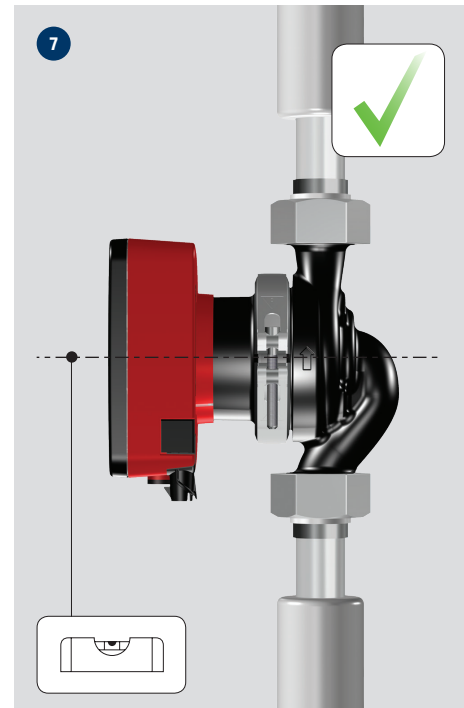
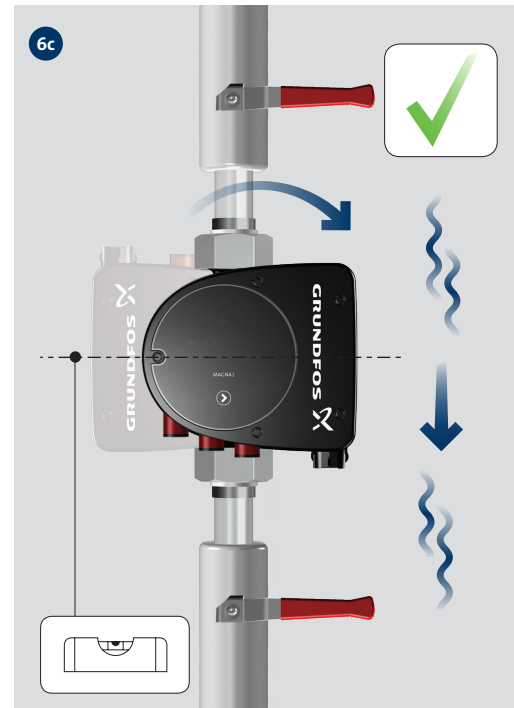
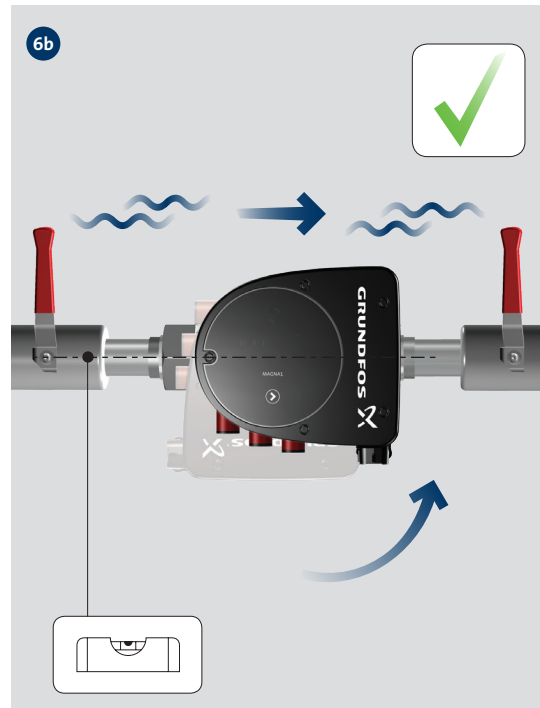
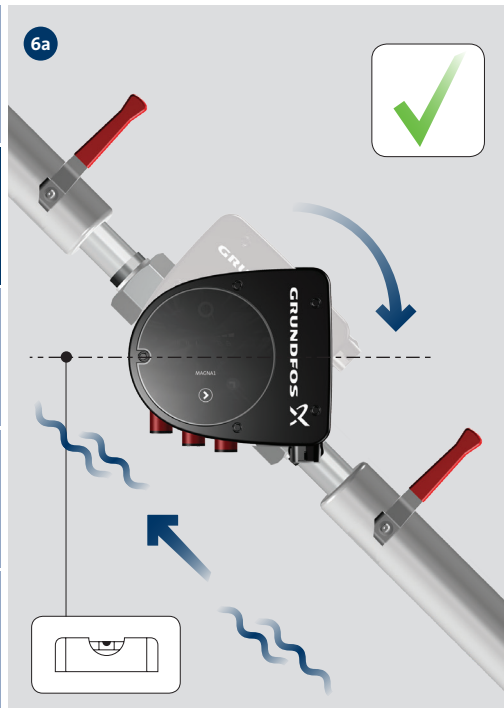



8

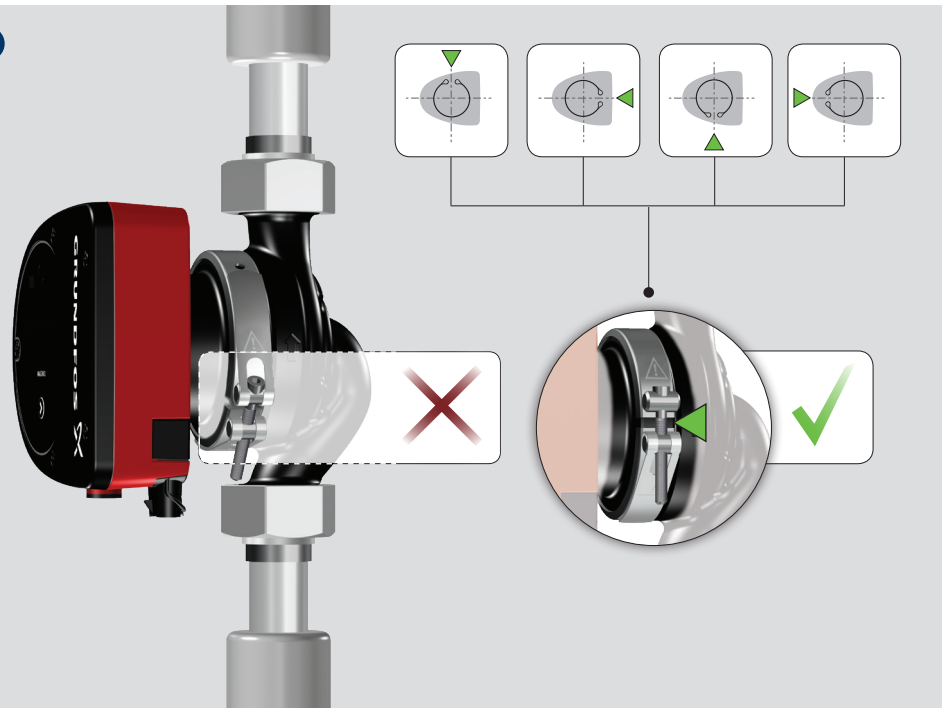

9

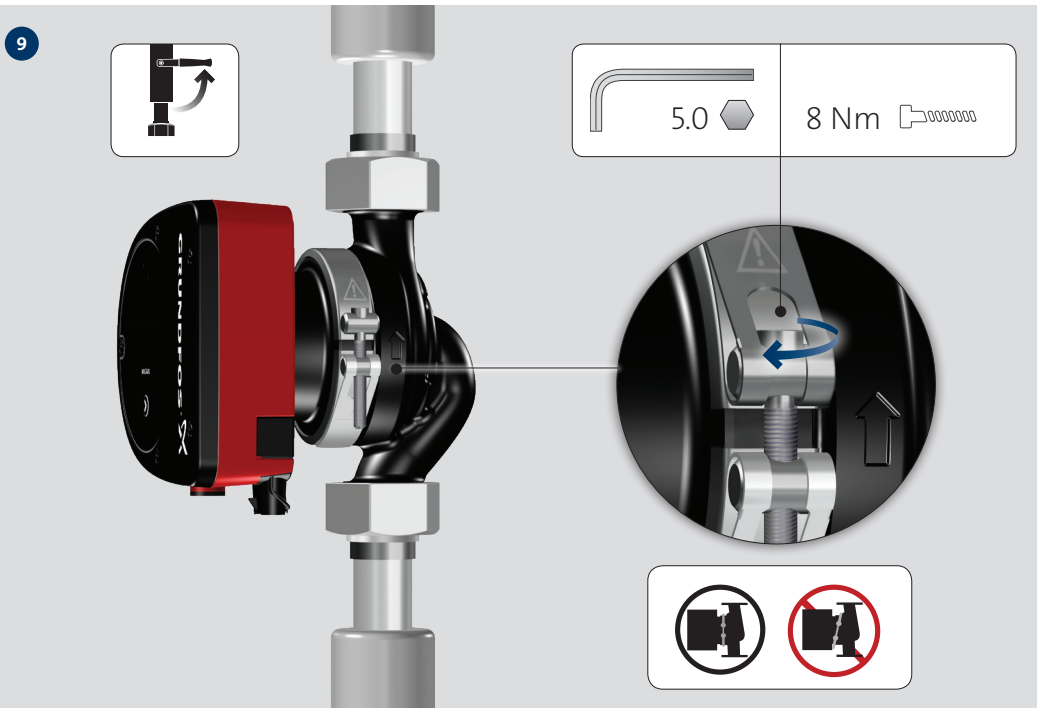



10

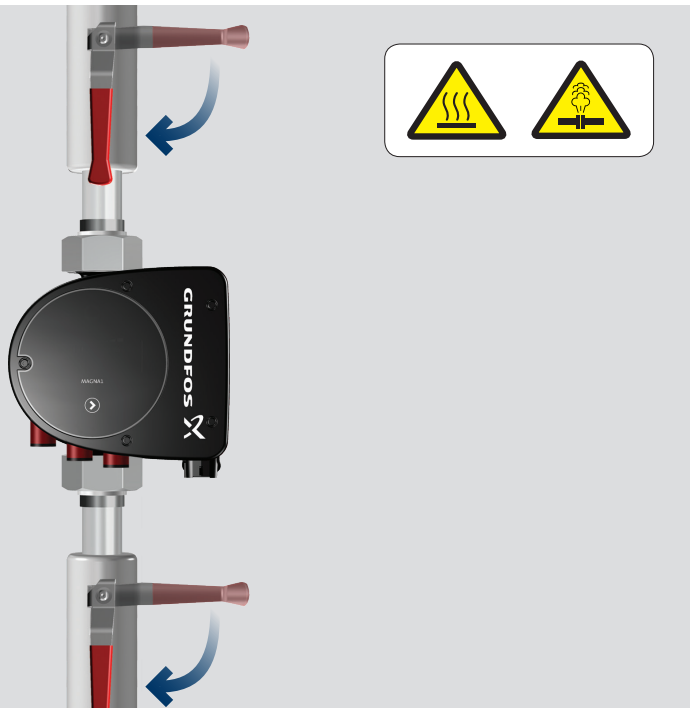

11

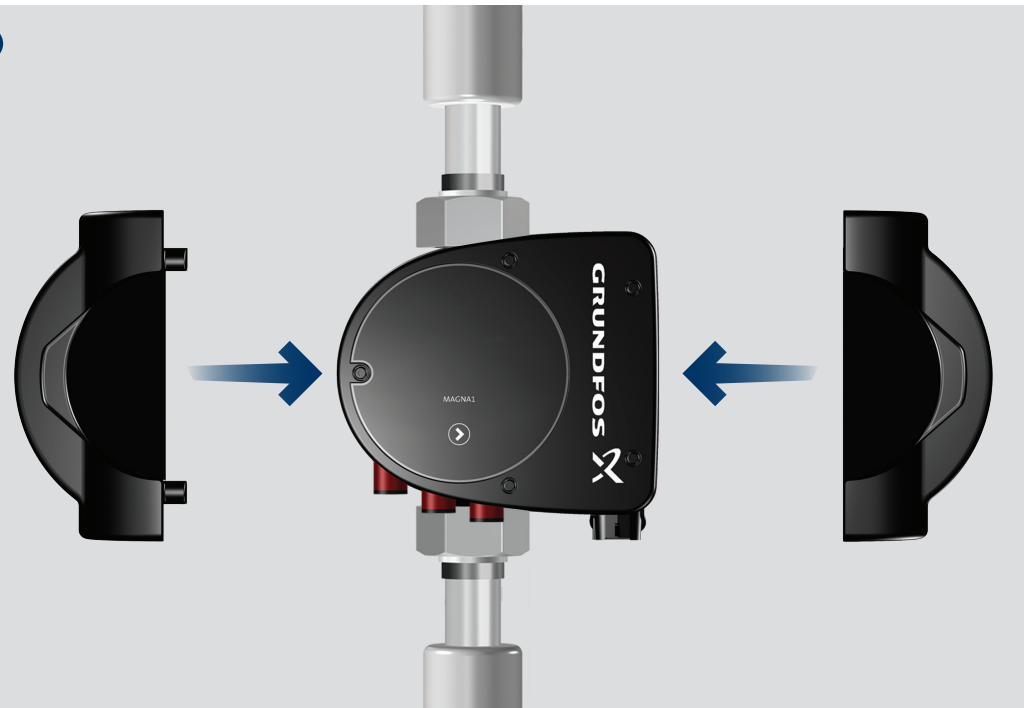



12

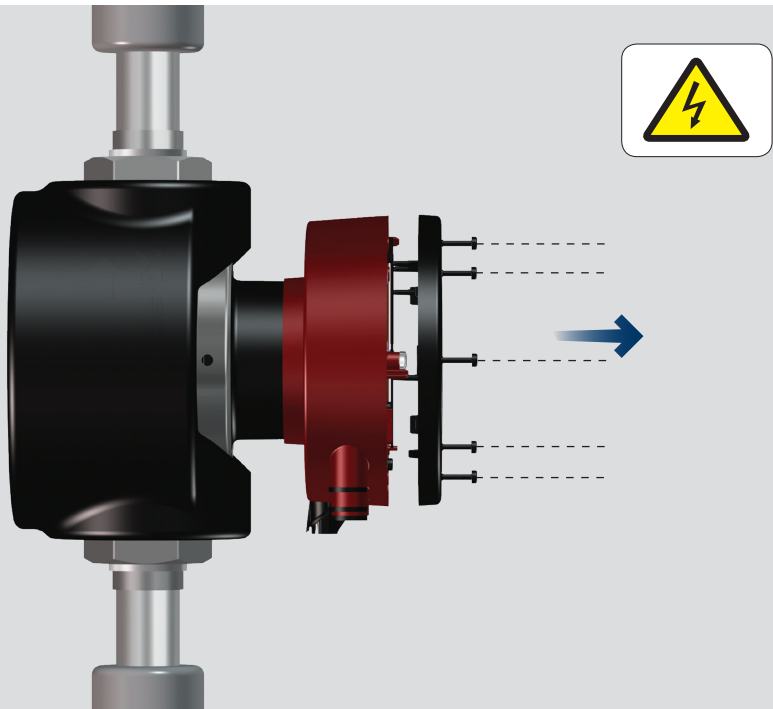

i

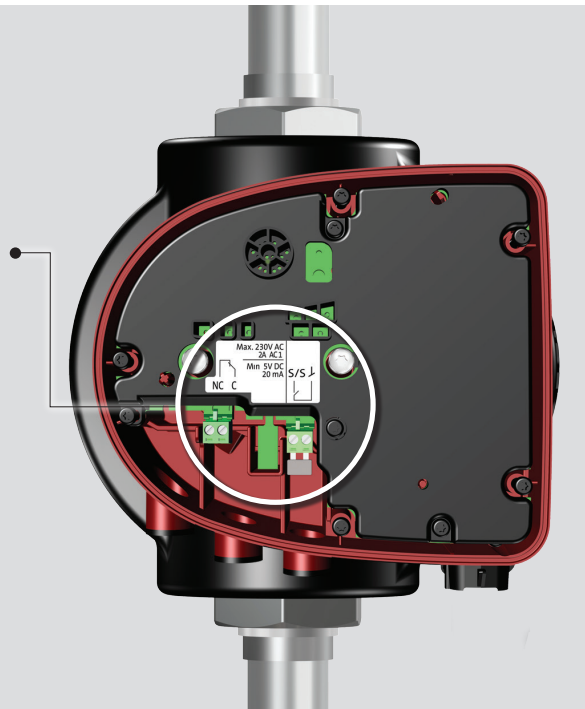
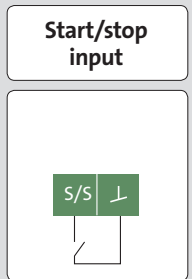
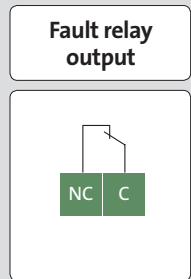



Fault relay
output

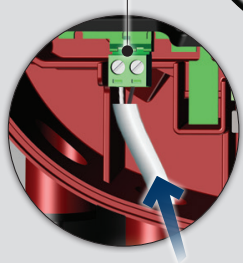

Start/stop
input

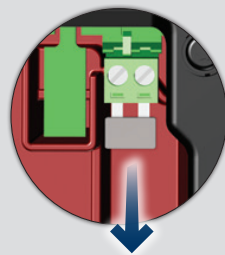

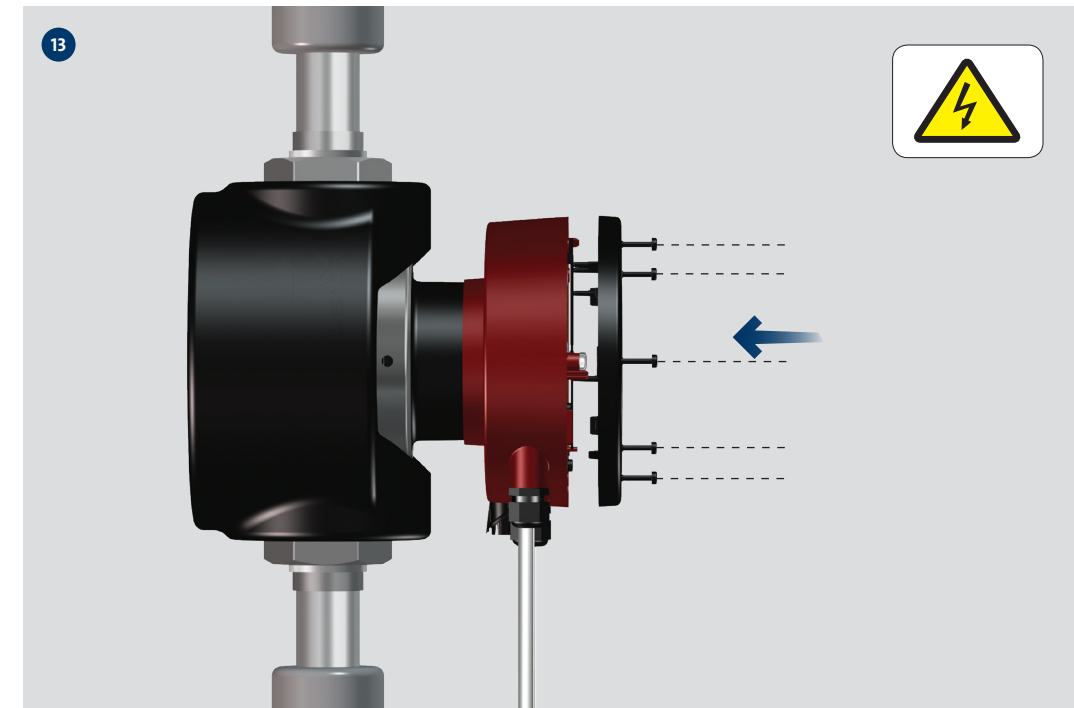
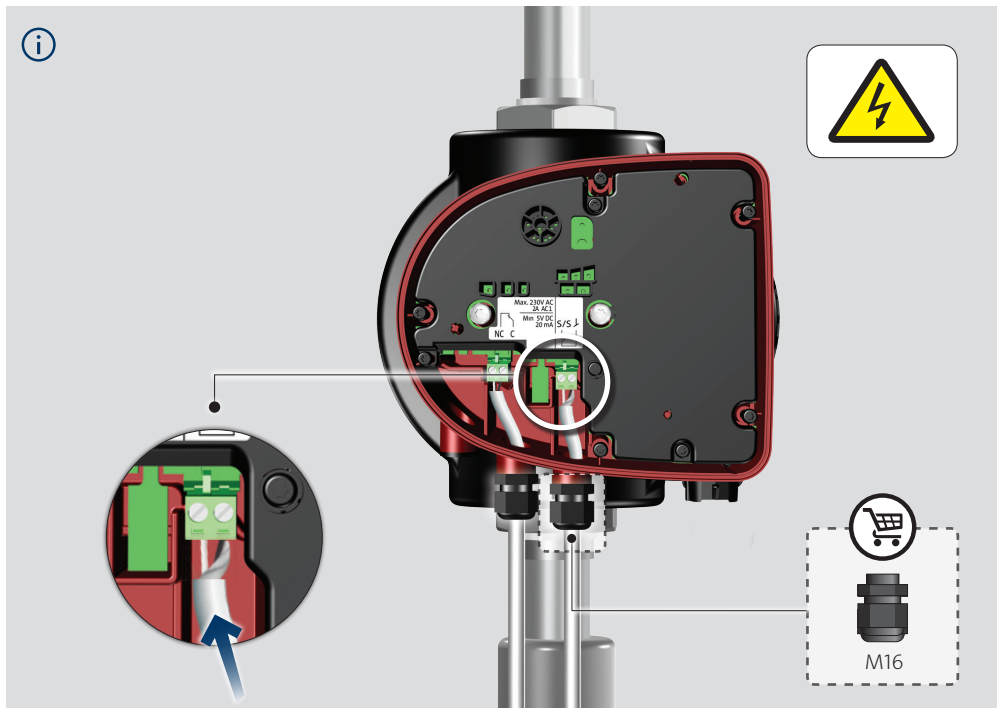

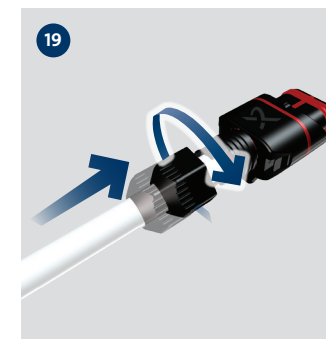
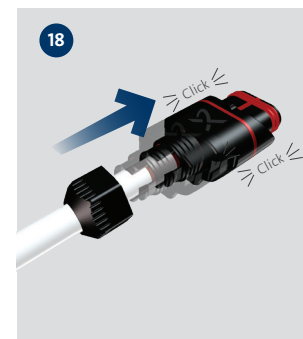
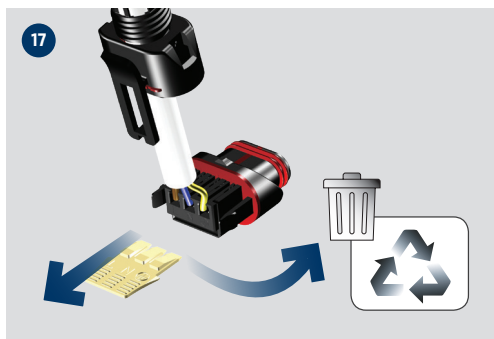
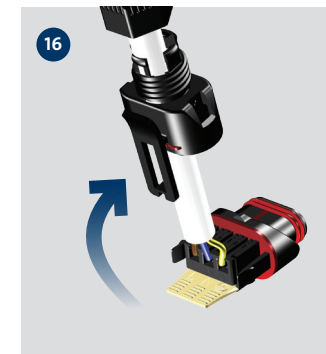
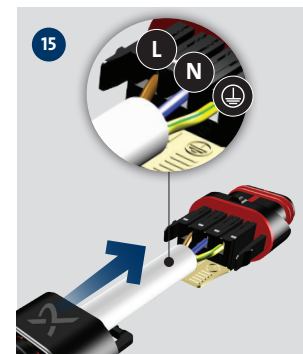
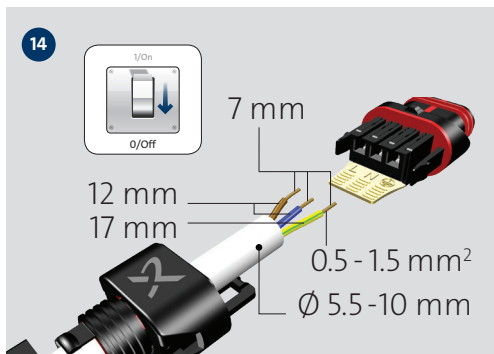



21



i

Power cycle
Max. 4 starts
per 60 minutes



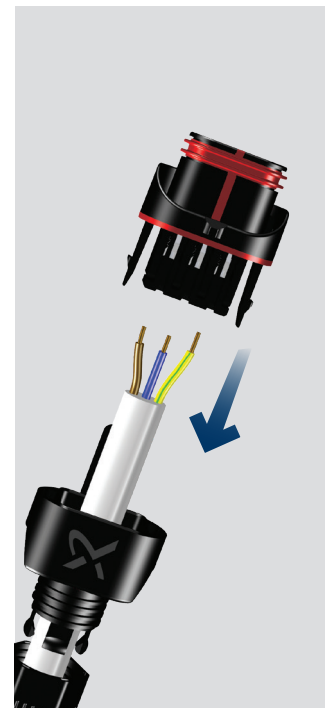
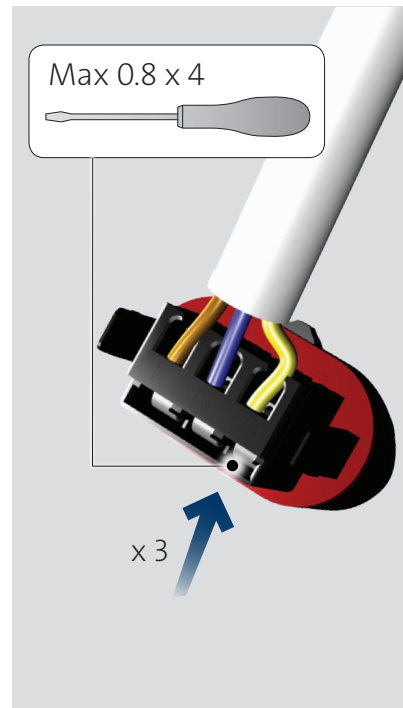
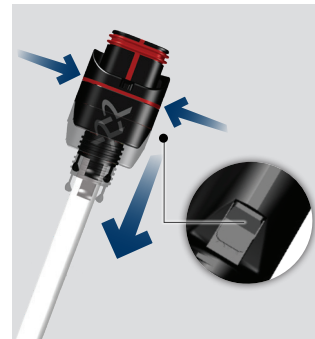
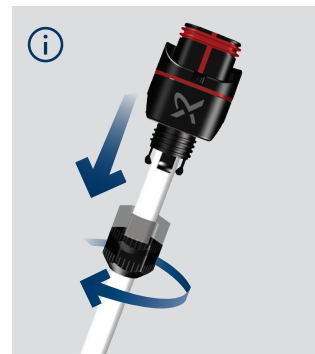



i

IR



IR

IR

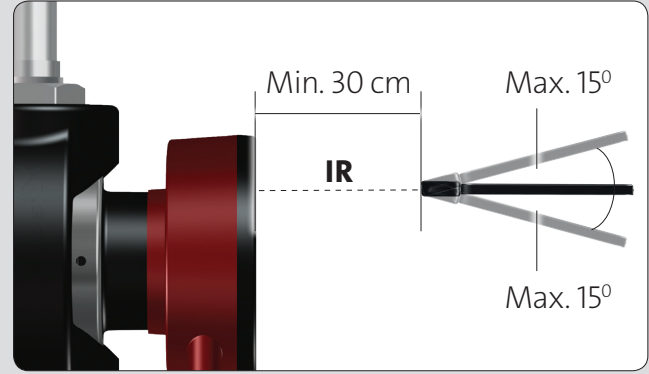
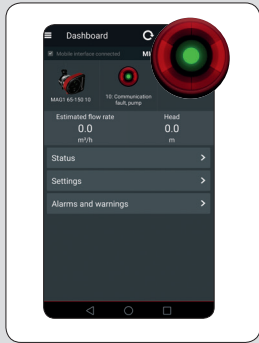

net.grundfos.com/qr/i/99209952



i

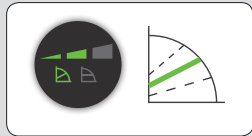

1X

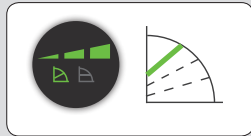

2X

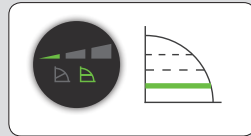

3X



4X



5X

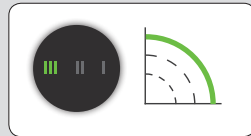

6X

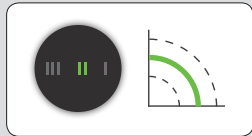

7X

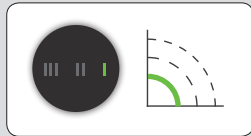

8X

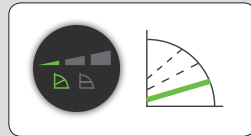

i

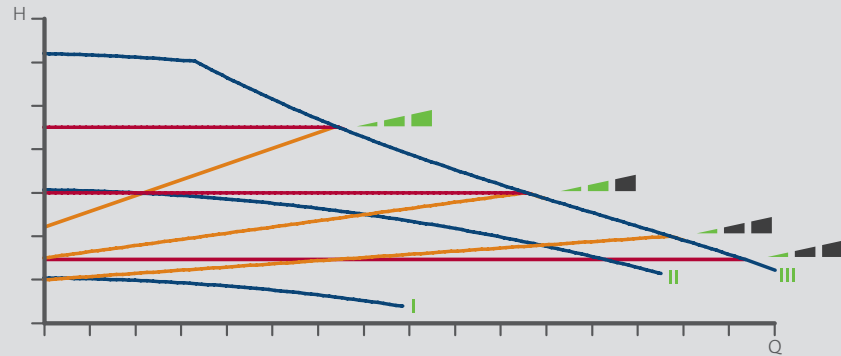

net.grundfos.com/qr/i/99209952

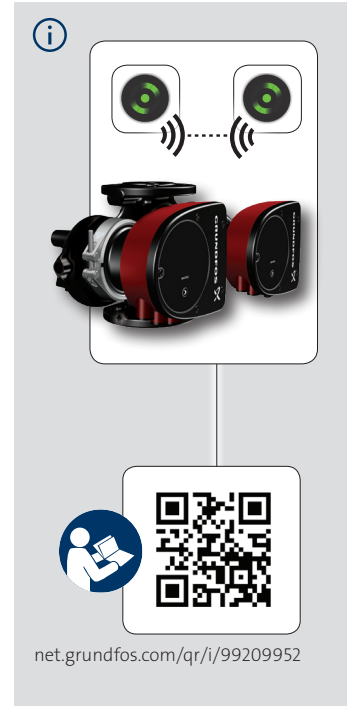
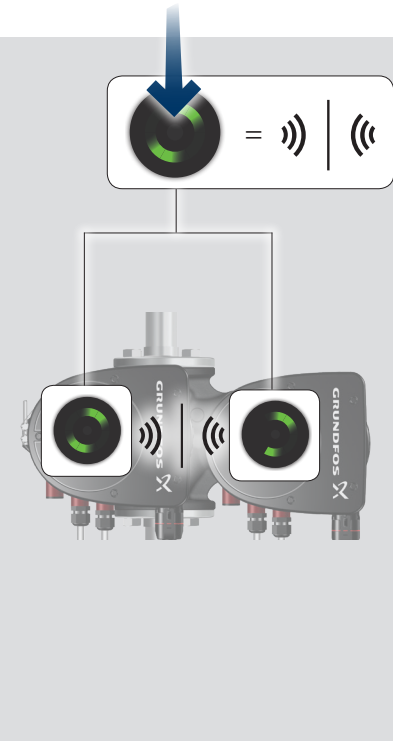
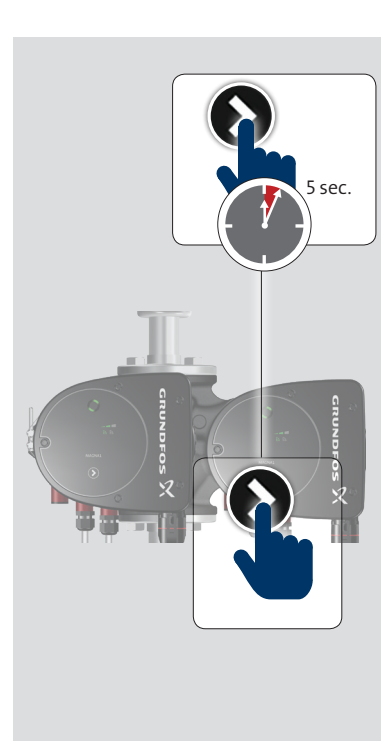
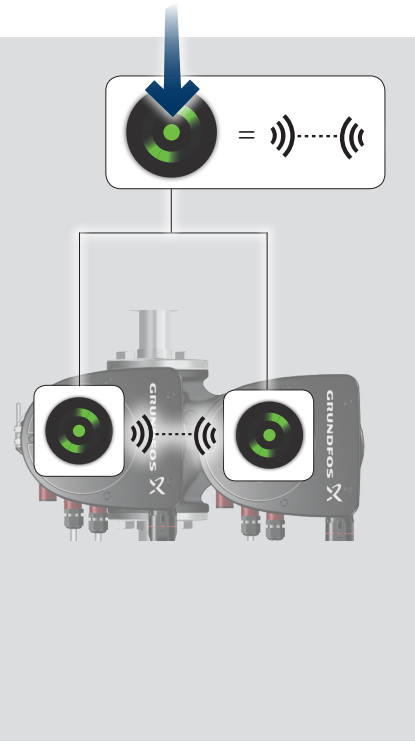
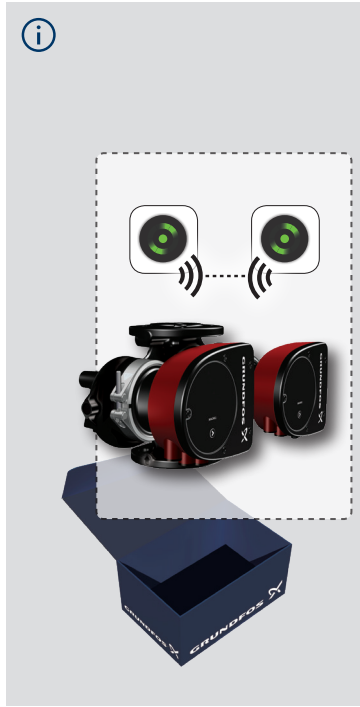

Installation date: _____

Installer:

99334333 0219

ECM: 1253737

GRUNDFOS Holding A/S
Poul Due Jensens Vej 7
DK-8850 Bjerringbro
Tel: +45 87 50 14 00
www.grundfos.com