

MAGNA3

Plug-connected versions / Control box - Front cover

Service kit instructions



be
think
innovate

GRUNDFOS X

English (GB) Service kit instructions

CONTENTS

Page

1. Control box	8
1.1 Dismantling the control box	8
1.2 Assembling the control box	12
2. Front cover	25
2.1 Dismantling the front cover	25
2.2 Assembling the front cover	28

English (GB)



Warning

Before starting service work, read the safety instructions supplied with the product.



Warning

Always use an antistatic service kit when handling electronic components. This will prevent static electricity from damaging components. See figure below.

When unprotected, the component must be placed on the antistatic cloth.

Dansk (DK)



Advarsel

Læs sikkerhedsanvisningerne der blev leveret med produktet, før du foretager servicearbejde.



Advarsel

Brug altid et antistatisk servicesæt når du håndterer elektroniske komponenter. Dette forhindrer at komponenter beskadiges af statisk elektricitet. Se nedenstående figur.

Når komponenten er ubeskyttet, skal den placeres på det antistatiske klæde.

Deutsch (DE)**Warnung**

Vor der Durchführung irgendwelcher Reparaturarbeiten ist die mit dem Produkt mitgelieferte Serviceanleitung sorgfältig durchzulesen.

Warnung

Beim Umgang mit elektronischen Bauteilen ist immer ein antistatischer Erdungsreparatursatz zu verwenden. Dadurch wird verhindert, dass die Bauteile durch statische Entladung beschädigt werden. Siehe nachfolgende Abbildung.

Wird kein entsprechender Schutz getragen, sind die Bauteile auf einem antistatischen Tuch abzulegen.

Ελληνικά (GR)**Ειδοποίηση**

Πριν ξεκινήσετε εργασίες επισκευής, διαβάστε τις οδηγίες ασφαλείας που συνοδεύουν το προϊόν.

Ειδοποίηση

Χρησιμοποιείτε πάντα ένα αντιστατικό service kit όταν διαχειρίζεστε ηλεκτρονικά εξαρτήματα. Έτσι θα αποφύγετε ο στατικός ηλεκτρισμός να καταστρέψει εξαρτήματα. Βλέπε εικόνα παρακάτω.

Το εξάρτημα να παραμένει στο προστατευτικό αντιστατικό ύφασμα όταν δεν προστατεύεται.

Español (ES)**Advertencia**

Antes de comenzar el trabajo, lea las instrucciones de seguridad suministradas con el producto.

Advertencia

Utilice siempre un kit de servicio antiestático cuando maneje componentes electrónicos. Esto evitará que la electricidad estática pueda dañar las piezas. Véase la figura siguiente.

Cuando esté sin protección, la pieza debe ser colocada sobre el paño antiestático.

Français (FR)

Avertissement

Avant toute intervention, consulter les consignes de maintenance fournies avec le produit.



Avertissement

Toujours utiliser un kit de maintenance antistatique lors de la manipulation de composants électroniques. Cela évite que l'électricité statique n'endommage les composants. Voir figure ci-dessous.

Lorsqu'il n'est pas protégé, le composant doit être placé sous un tissu antistatique.

Italiano (IT)

Avviso

Prima di iniziare i lavori di manutenzione, leggere le istruzioni di sicurezza fornite con il prodotto.



Avviso

Utilizzare sempre un kit antistatico quando si maneggiano componenti elettronici. Ciò impedirà all'elettricità statica di danneggiare i componenti. Vedi fig. seguente.

Quando non protetto, il componente deve essere appoggiato sul panno antistatico.

Nederlands (NL)

Waarschuwing

Lees de veiligheidsinstructies die bij het product meegeleverd zijn voordat u begint met servicewerkzaamheden.



Waarschuwing

Gebruik altijd een antistatische serviceset bij het hanteren van elektronische componenten. Dit voorkomt dat statische elektriciteit componenten beschadigt. Zie onderstaande afbeelding.

Indien onbeschermd moet het component op de antistatische doek worden gelegd.

Português (PT)

Aviso

Antes de iniciar o serviço de manutenção, leia as instruções de segurança fornecidas com o produto.

Aviso

Utilize sempre um kit de manutenção antiestático quando lidar com componentes electrónicos. Isto irá prevenir que a electricidade estática danifique os componentes.



Observe a figura abaixo.

Quanto desprotegido, o componente deve ser colocado num pano antiestático.

Русский (RU)

Предупреждение

Перед началом работ по сервисному обслуживанию необходимо прочитать сервисное руководство, поставляемое с продуктом.

Предупреждение

При работе с электроникой всегда используйте антистатический сервисный комплект. Это поможет предотвратить повреждение компонентов статическим электричеством.



Смотрите рисунок ниже.

При отсутствии защиты компоненты необходимо размещать на антистатической ткани.

Suomi (FI)

Varoitus

Lue tuotteen mukana toimitetut turvallisuusohjeet ennen huoltotöiden aloittamista.

Varoitus

Käytä aina antistaattista huoltosarjaa, kun käsittelet elektronisia komponentteja. Tämä estää staattisen sähkön aiheuttaman komponenttien vaurioitumisen. Katso alla olevaa kuvaa.



Suojaamattomana komponentti on asetettava antistaattisen liinan päälle.

Svenska (SE)



Varning

Läs de säkerhetsanvisningar som medföljer produkten innan servicearbetet inleds.



Varning

Använd alltid ett antistatiskt servicekit vid hantering av elektroniska komponenter. Det förhindrar att komponenter skadas av statisk elektricitet. Se figur nedan.

Oskyddade komponenter ska placeras på den antistatiska duken.

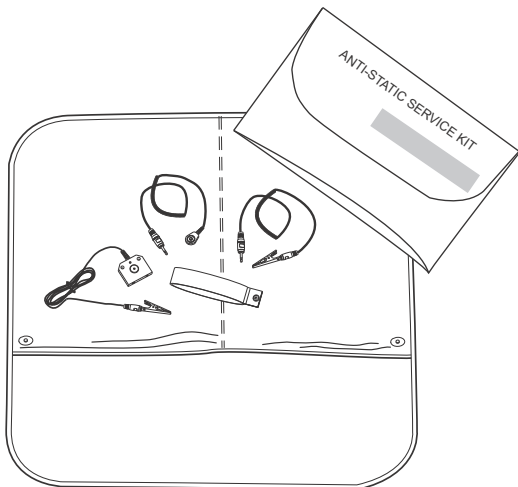

TM05 8838 2813

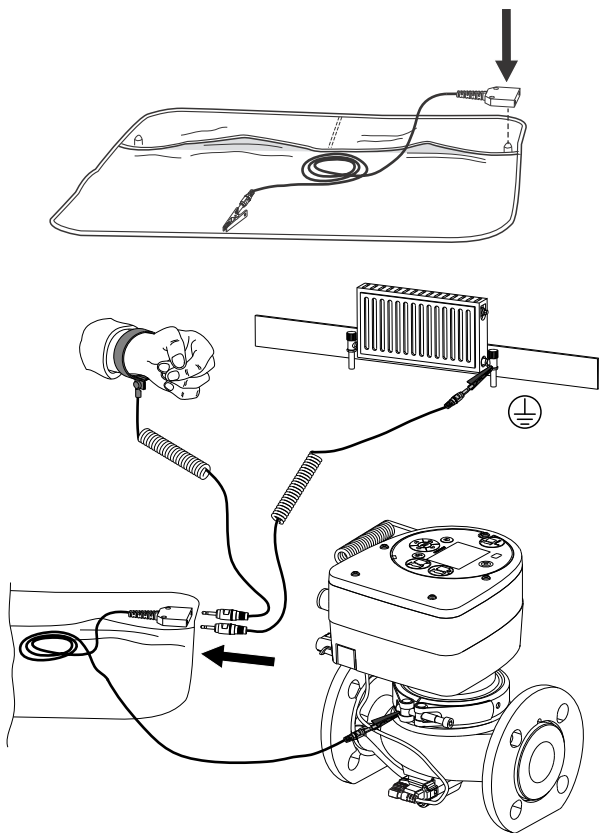

TM05 8771 2713

TM06 9705 3017

1. Control box

1.1 Dismantling the control box

DK: Adskillelse af kontrolboksen

DE: Demontage des Schaltkastens

GR: Αποσυναρμολόγηση του κιβωτίου ελέγχου

ES: Desmontaje de la caja de control

FR: Démontage du coffret de commande

IT: Smontaggio del quadro di controllo

NL: De schakelkast demonteren

PT: Desmontagem da caixa de comandos

RU: Демонтаж блока управления

FI: Ohjainlaitteen purkamisen osiin

SE: Demontering av styrenheten

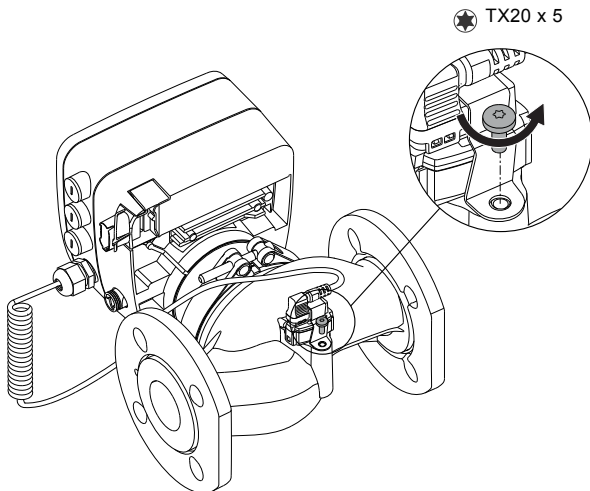

Fig. 1

TM06 9543 2517

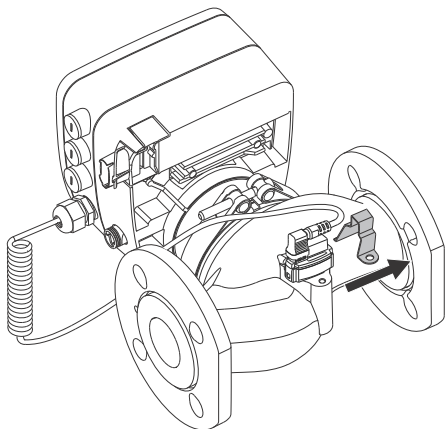

Fig. 2

TM06 9544 2517

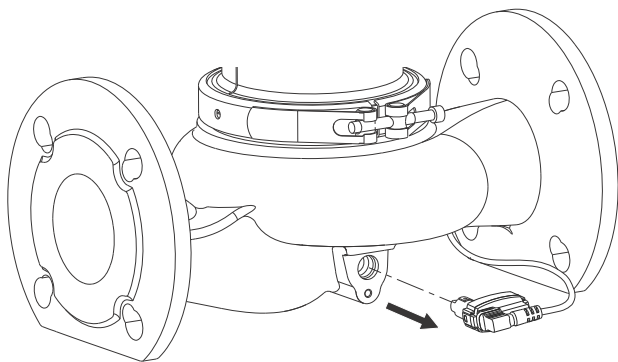

Fig. 3

TM06 9564 2517

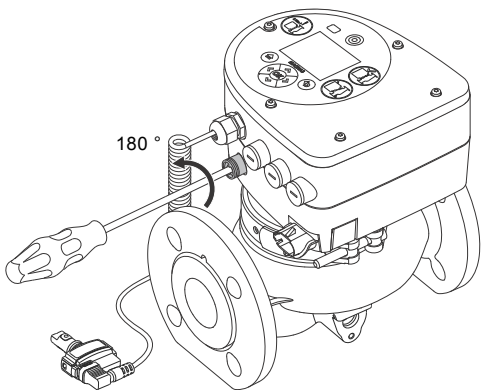

Fig. 4

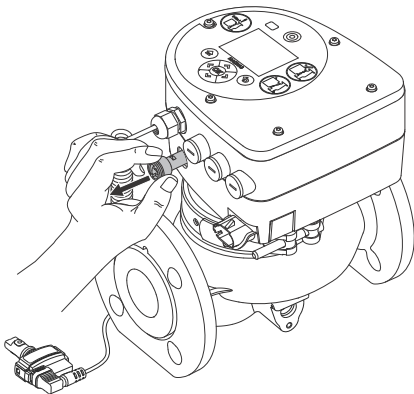

Fig. 5

TM06 9706 3017

TM06 9704 3017

TM06 9708 3017

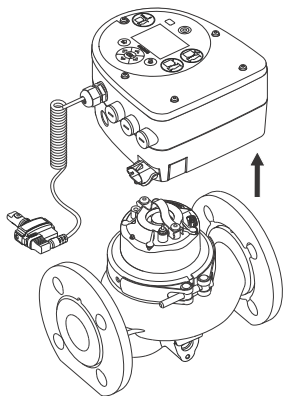

Fig. 6

1.2 Assembling the control box

DK: Samling af kontrolboksen

DE: Montage des Schaltkastens

GR: Συναρμολόγηση του κιβωτίου ελέγχου

ES: Montaje de la caja de control

FR: Montage du coffret de commande

IT: Montaggio del quadro di controllo

NL: De schakelkast monteren

PT: Montagem da caixa de comandos

RU: Монтаж блока управления

FI: Ohjainlaitteen asentaminen

SE: Montering av styrenheten

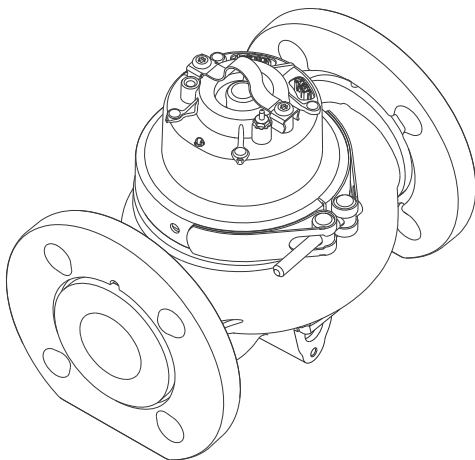

Fig. 1

TM06 9709 3017

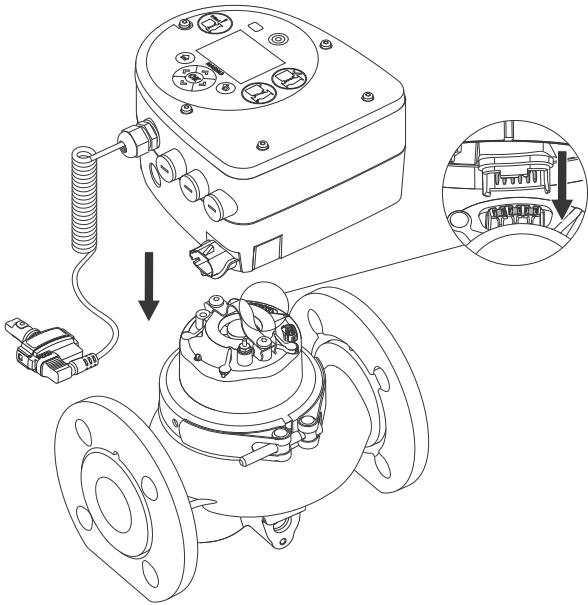

Fig. 2

TM06 9710 3017

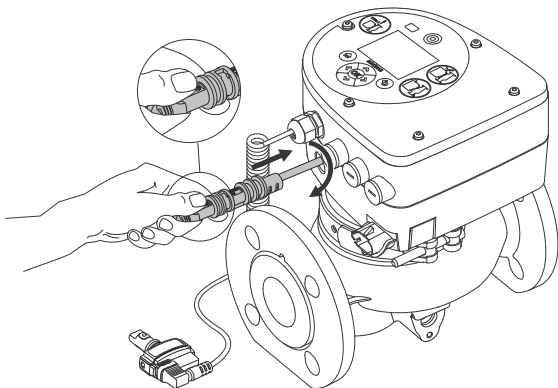

Fig. 3

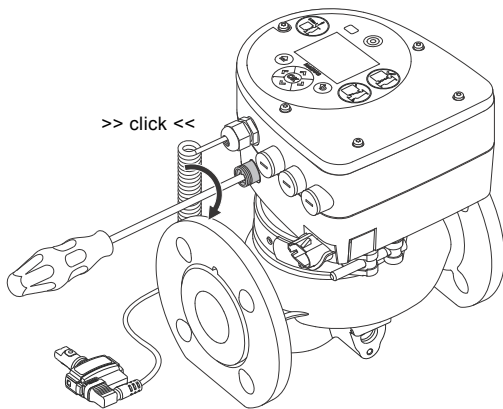

Fig. 4

TM06 9711 3017

TM06 9712 3017

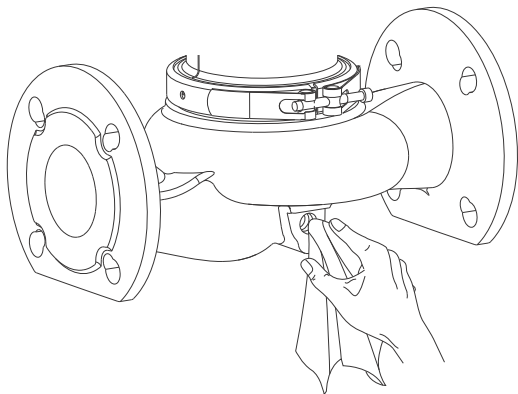

Fig. 5

TM06 9546 2517

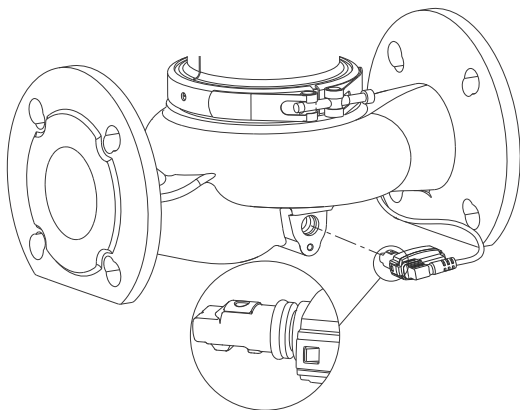

Fig. 6

TM06 9547 2517

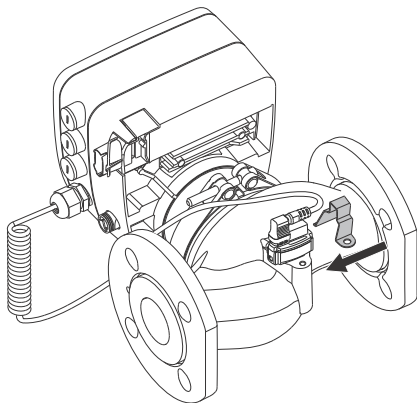

Fig. 7

TM06 9548 2517

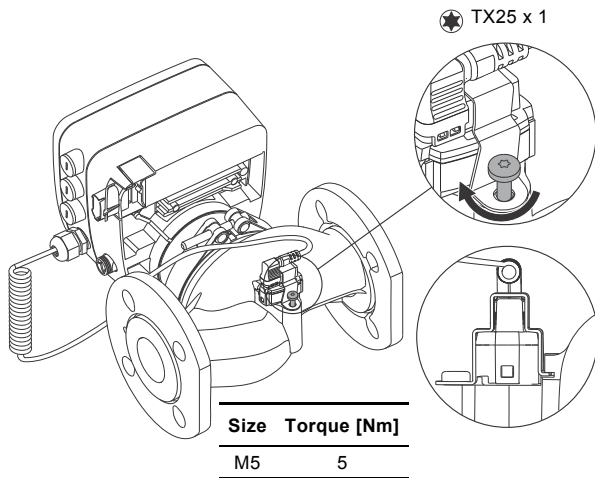

Fig. 8

TM05 8495 2213

PC =   +  

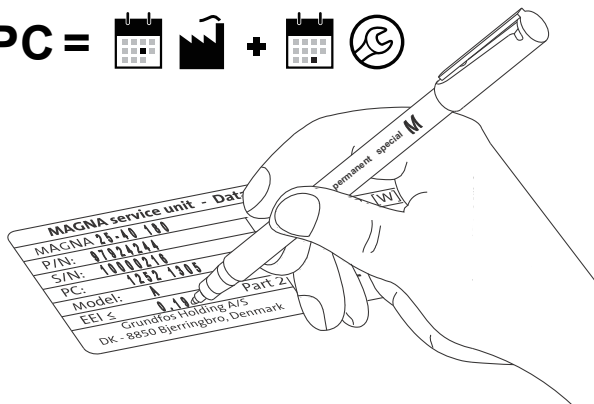

Fig. 9

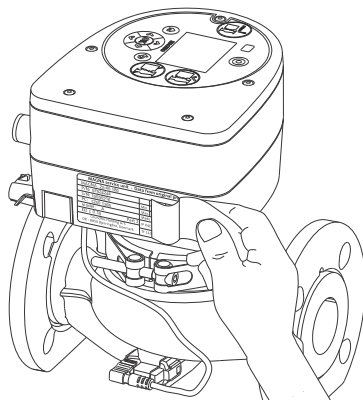
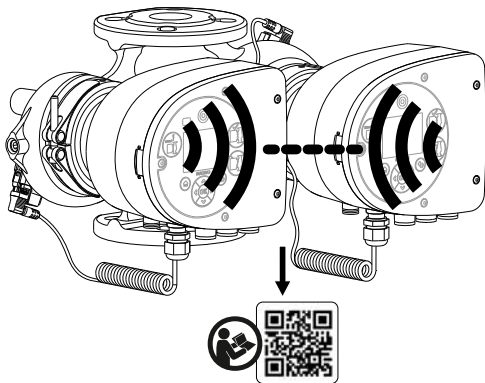

Fig. 10

TM05 8767 2613 - TM05 8265 2213

TM06 9713 3017



TM06 9714 3017

Fig. 11

English (GB)

Warning



If you replace a control box in a multipump system, make sure that the new control box, model C or newer, always is the master control box. Start the pump again. See section Multipump setup in the installation and operating instructions for the pump. If you use the inputs on one pump only, make sure they are on the master pump.

Dansk (DK)

Advarsel



Hvis du udskifter en kontrolboks i et flerpumpesystem, sørg da for at den nye kontrolboks, model C eller nyere, altid er masterkontrolboksen. Start pumpen igen. Se afsnittet Flerpumpeindstilling i monterings- og driftsinstruktionen for pumpen. Hvis du bruger indgangene på kun den ene pumpe, sørg da for at de er på masterpumpen.

Deutsch (DE)

Warnung

Wenn Sie den Schaltkasten in einer Mehrpumpenanlage austauschen, stellen Sie sicher, dass der neue Schaltkasten (Modell C oder neuer) immer als Master-Schaltkasten fungiert. Schalten Sie die Pumpe wieder ein. Siehe den Abschnitt zur Mehrpumpenkonfiguration in der Montage- und Betriebsanleitung der Pumpe. Wenn Sie Eingänge an nur einer Pumpe verwenden, stellen Sie sicher, dass es sich dabei um die Master-Pumpe handelt.

**Ελληνικά (GR)**

Ειδοποίηση

Σε περίπτωση αντικατάστασης ενός κιβωτίου ελέγχου σε σύστημα πολλών αντλιών, βεβαιωθείτε ότι το καινούργιο κιβώτιο ελέγχου, μοντέλο C ή μεταγενέστερο, είναι πάντα το κύριο κιβώτιο ελέγχου. Εκκινήστε και πάλι την αντλία. Βλέπε το κεφάλαιο Ρύθμιση πολλών αντλιών στις οδηγίες εγκατάστασης και λειτουργίας της αντλίας. Εάν χρησιμοποιείτε τις εισόδους σε μία μόνο αντλία, βεβαιωθείτε ότι αυτές βρίσκονται πάνω στην κύρια αντλία.

**Español (ES)**

Advertencia

Si sustituye una caja de control que forme parte de un sistema multibomba, asegúrese de que la nueva caja de control (modelo C o posterior) sea la caja de control maestra. Arranque la bomba de nuevo. Consulte la sección "Configuración multibomba" en las instrucciones de instalación y funcionamiento de la bomba. Si sólo usa las entradas de una bomba, asegúrese de que no sean las de la bomba maestra.

**Français (FR)**

Avertissement

Si vous remplacez un coffret de commande dans une installation multipompe, s'assurer que le nouveau coffret (modèle C ou ultérieur), est toujours le coffret de commande principal (maître). Démarrer à nouveau la pompe. Voir le paragraphe relatif à la configuration multipompe dans la notice d'installation et de fonctionnement de la pompe. Si vous utilisez les entrées d'une seule pompe, s'assurer qu'elles figurent sur la pompe maîtresse.



Italiano (IT)

Avviso



Se si sostituisce un quadro di controllo in un sistema multipompa, assicurarsi che il nuovo quadro di controllo, modello C o più recente, sia sempre quello principale. Riavviare la pompa. Consultare la sezione Configurazione multipompa nelle istruzioni di installazione e funzionamento della pompa. Se si utilizzano gli ingressi su una sola pompa, assicurarsi che siano sulla pompa principale.

Nederlands (NL)

Waarschuwing



Als u een schakelkast in een multipompsysteem vervangt, zorgt u ervoor dat de nieuwe schakelkast, model C of nieuwer, altijd de hoofdschakelkast is. Schakel de pomp opnieuw in. Zie de sectie Multipompsysteem instellen in de installatie- en bedieningsinstructies voor de pomp. Als u de ingangen op slechts één pomp gebruikt, controleert u of deze zich op de hoofdpomp bevinden.

Português (PT)

Aviso



Substituir caixa de terminais por caixa de comandos, certifique-se de que a nova caixa de comandos, de modelo C ou mais recente, é sempre a caixa de comandos principal. Reinicie a bomba. Consulte a secção Configuração Multibombas nas instruções de instalação e funcionamento da bomba. Se utilizar as entradas apenas de uma bomba, certifique-se de que são as da bomba principal.

Русский (RU)

Предупреждение



Если выполняется замена блока управления в многонасосной системе, убедитесь, что новый блок управления модели C или более новой модели обязательно является главным шкафом управления. Запустите насос повторно. См. раздел "Многонасосная система" в Паспорте, Руководстве по монтажу и эксплуатации конкретного насоса. Если используются входы только на одном насосе, убедитесь, что они находятся на главном насосе.

Suomi (FI)

Varoitus



Jos vaihdat monipumppujärjestelmän ohjainlaitetta, määritä uusi ohjainlaite (malli C tai uudempi) aina pääohjainlaitteeksi (master). Käynnistä pumppu uudelleen. Lue pumpun asennus- ja käyttöohjeesta monipumppujärjestelmän asetuksia koskeva luku. Jos käytät vain yhden pumpun tuloja, käytä ehdottomasti masterpumpun tuloja.

Svenska (SE)

Varning



Om du byter ut styrenheten i ett flerpumpssystem ska du se till att den nya styrenheten, modell C eller nyare alltid är masterstyrenheten. Starta pumpen igen. Se avsnittet flerpumpsinställning i monterings- och driftsinstruktionen för pumpen. Om du endast använder ingångarna på en pump ska du se till att det är på masterpumpen.

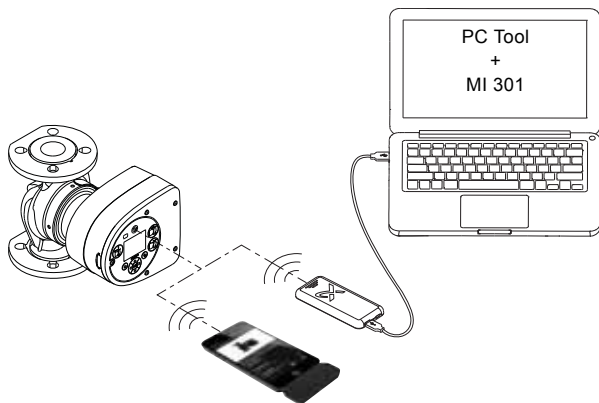

Fig. 12

TM06 9715 3017

English (GB)

Warning



Check the label on the packaging. If the control box is configured, it is stated with the text w/sw (with software).

If the control box is not configured, configure the pump by means of PC Tool and MI 301 or Grundfos GO. See the service instructions for the product.

Dansk (DK)

Advarsel



Kontrollér mærkatet på emballagen. Hvis kontrolboksen er konfigureret, fremgår det med teksten w/sw (med software).

Hvis kontrolboksen ikke er konfigureret, konfigurér pumpen ved hjælp af PC Tool og MI 301 eller Grundfos GO. Se serviceinstruktionen til produktet.

Deutsch (DE)

Warnung



Überprüfen Sie das Etikett auf der Verpackung. Wenn der Schaltkasten vorkonfiguriert ist, wird dies durch w/sw (with Software) angegeben.

Wenn der Schaltkasten nicht vorkonfiguriert ist, müssen Sie die Pumpe mithilfe von PC-Tool, MI 301 oder Grundfos GO konfigurieren. Siehe die Wartungsanleitung des Produkts.

Ελληνικά (GR)

Ειδοποίηση



Ελέγξτε την ετικέτα στη συσκευασία. Εάν το κιβώτιο ελέγχου είναι διαμορφωμένο, αυτό θα δηλώνεται με το κείμενο "w/sw" (με λογισμικό).

Εάν το κιβώτιο ελέγχου δεν είναι διαμορφωμένο, διαμορφώστε την αντλία μέσω του PC Tool και της MI 301 ή του Grundfos GO. Βλέπε τις οδηγίες σέρβις του προϊόντος.

Español (ES)

Advertencia

Consulte la etiqueta que incluye el embalaje. Si la caja de control está configurada, se indicará con el texto "w/sw" (abreviatura en inglés de "con software").



Si la caja de control no está configurada, configure la bomba empleando la herramienta PC Tool y la interfaz MI 301, o bien Grundfos GO. Consulte las instrucciones de mantenimiento del producto.

Français (FR)

Avertissement

Vérifier l'étiquette sur l'emballage. Si le coffret de commande est configuré, cela est indiqué par la mention w/sw (avec logiciel).



Si le coffret de commande n'est pas configuré, configurer la pompe avec PC Tool, MI 301 ou Grundfos GO. Consulter la notice de maintenance de l'appareil.

Italiano (IT)

Avviso

Controllare l'etichetta sull'imballaggio. Se il quadro di controllo è configurato, viene indicato con il testo w/sw (con software).



Se il quadro di controllo non è configurato, configurare la pompa tramite PC Tool e MI 301 o Grundfos GO. Consultare le istruzioni di manutenzione del prodotto.

Nederlands (NL)

Waarschuwing

Controleer het label op de verpakking. Als de schakelkast is geconfigureerd, wordt dit aangeduid met de tekst w/sw (met software).



Als de schakelkast niet is geconfigureerd, configureert u de pomp via PC Tool en MI 301 of met Grundfos GO. Zie de service-instructies voor het product.

Português (PT)

Aviso



Verifique a etiqueta na embalagem. Substituir caixa de terminais por caixa de comandos, isso será assinalado pelo texto "w/sw" (com software).

Se a caixa de comandos não estiver configurada, configure a bomba através da ferramenta informática PC Tool e do MI 301 ou do Grundfos GO. Manuais de instrução e operação.

Русский (RU)

Предупреждение



Проверьте ярлык на упаковке. Если блок управления сконфигурирован, имеется обозначение "w/sw" (с программным обеспечением).

Если блок управления не сконфигурирован, выполните конфигурирование насоса при помощи PC Tool и MI 301 или Grundfos GO. См. сервисные инструкции на изделие.

Suomi (FI)

Varoitus



Lue laitteen pakkausmerkinnät. Jos ohjainlaite on konfiguroitu tehtaalla, pakkauksessa on teksti "w/sw" (sisältää ohjelmiston).

Jos ohjainlaitetta ei ole konfiguroitu valmiiksi, konfiguroi pumppu PC Tool -sovelluksella ja MI 301 -laitteella tai Grundfos GO Remote -mobiilisovelluksella. Lue laitteen huolto-ohjeet.

Svenska (SE)

Varning



Kontrollera etiketten på förpackningen. Om styrenheten är konfigurerad, anges det med texten w/sw (med programvara).

Om styrenheten inte är konfigurerad ska pumpen konfigureras. Se serviceinstruktionen för produkten.

2. Front cover

2.1 Dismantling the front cover

DK: Adskillelse af frontplade

NL: Het voordeksel demonteren

DE: Demontage der Frontplatte

PT: Desmontagem da cobertura frontal

GR: Αποσυναρμολόγηση του μπροστινού καπακιού

RU: Демонтаж передней крышки

ES: Desmontaje de la cubierta delantera

FI: Etukannen irrottaminen

FR: Démontage de la façade

SE: Demontering av den främre kåpan

IT: Smontaggio del coperchio frontale

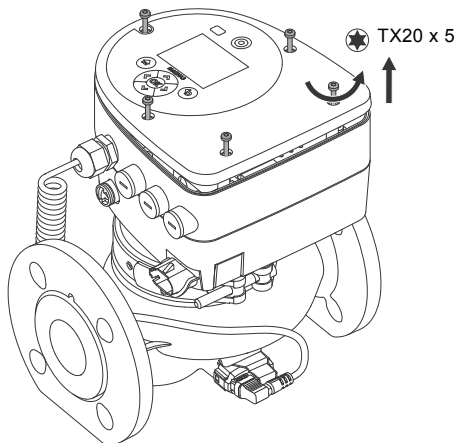

Fig. 1

TM06 9737 3017

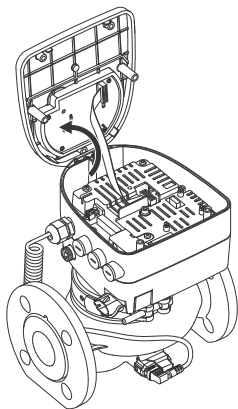

Fig. 2

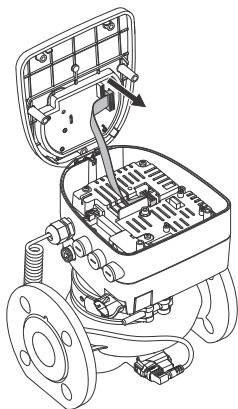

Fig. 3

TM06 9738 3017

TM06 9739 3017

TM06 9740 3017

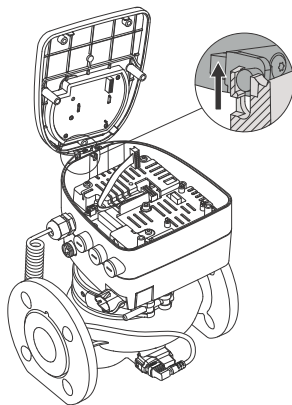

Fig. 4

2.2 Assembling the front cover

DK: Samling af frontplade	NL: Het voordeksel monteren
DE: Montage der Frontplatte	PT: Montagem da cobertura frontal
GR: Συναρμολόγηση του μπροστινού καπακιού	RU: Монтаж передней крышки
ES: Montaje de la cubierta delantera	FI: Etukannen kiinnittäminen
FR: Montage de la façade	SE: Montering av den främre kåpan
IT: Montaggio del coperchio frontale	

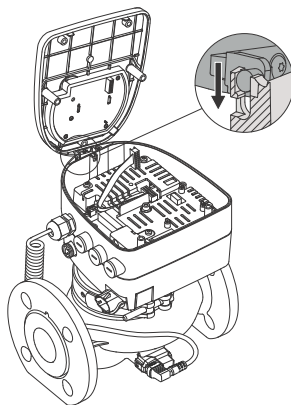

Fig. 1

TM06 9741 3017

TM06 9742 3017

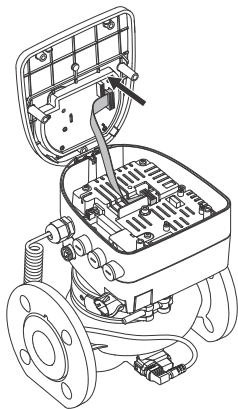

Fig. 2

TM06 9743 3017

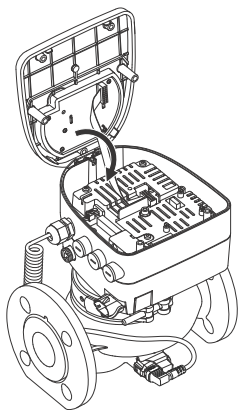

Fig. 3

Size	Torque [Nm]
M4	1.2

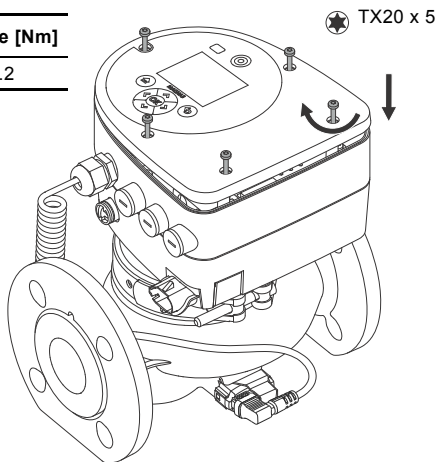

Fig. 4

TM06 9744 3017

Argentina

Bombas GRUNDFOS de
Argentina S.A.
Phone: +54-3327 414 444
Telefax: +54-3327 411 111

Australia

GRUNDFOS Pumps Pty. Ltd.
Phone: +61-8-8461-4611
Telefax: +61-8-8340 0155

Austria

GRUNDFOS Pumpen
Vertrieb Ges.m.b.H.
Tel.: +43-6246-883-0
Telefax: +43-6246-883-30

Belgium

N.V. GRUNDFOS Bellux S.A.
Tél.: +32-3-870 7300
Télécopie: +32-3-870 7301

Belarus

Представительство
ГРУНДФОС в Минске
Тел.: +7 (375 17) 286 39
72, 286 39 73
Факс: +7 (375-17) 286 39
71

**Bosnia and
Herzegovina**

GRUNDFOS Sarajevo
Phone: +387 33 592 480
Telefax: +387 33 590 465
www.ba.grundfos.com
email: grundfos@bih.net.ba

Brazil

BOMBAS GRUNDFOS DO
BRASIL
Phone: +55-11 4393 5533
Telefax: +55-11 4343 5015

Bulgaria

Grundfos Bulgaria EOOD
Tel. +359 2 49 22 200
Fax. +359 2 49 22 201

Canada

GRUNDFOS Canada Inc.
Phone: +1-905 829 9533
Telefax: +1-905 829 9512

China

GRUNDFOS Pumps
(Shanghai) Co. Ltd.
Phone: +86-021-612 252 22
Telefax: +86-021-612 253 33

COLOMBIA

GRUNDFOS Colombia
S.A.S.
Phone: +57(1)-2913444
Telefax: +57(1)-8764586

Croatia

GRUNDFOS CROATIA
d.o.o.
Phone: +385 1 6595 400
Telefax: +385 1 6595 499

GRUNDFOS Sales

**Czechia and
Slovakia s.r.o.**
Phone: +420-585-716 111

Denmark

GRUNDFOS DK A/S
Tlf.: +45-87 50 50 50
E-mail:
info_GDK@grundfos.com
www.grundfos.com/DK

Estonia

GRUNDFOS Pumps Eesti
OÜ
Tel: + 372 606 1690
Fax: + 372 606 1691

Finland

OY GRUNDFOS Pumput AB
Phone: +358-(0)207 889 500

France

Pompes GRUNDFOS
Distribution S.A.
Tél.: +33-4 74 82 15 15
Télécopie: +33-4 74 94 10 51

Germany

GRUNDFOS GMBH
Tel.: +49-(0) 211 929 69-0
e-mail:
infoservice@grundfos.de
Service in Deutschland:
e-mail:
kundendienst@grundfos.de

Greece

GRUNDFOS Hellas
A.E.B.E.
Phone: +0030-210-66 83
400
Telefax: +0030-210-66 46
273

Hong Kong

GRUNDFOS Pumps (Hong
Kong) Ltd.
Phone: +852-27861706/
27861741
Telefax: +852-27858664

Hungary

GRUNDFOS Hungária Kft.
Phone: +36-23 511 110
Telefax: +36-23 511 111

India

GRUNDFOS Pumps India
Private Limited
Phone: +91-44 4596 6800

Indonesia

PT GRUNDFOS Pompa
Phone: +62 21-469 51900
Telefax: +62-21-460 6910/
460 6901

Ireland

GRUNDFOS (Ireland) Ltd.
Phone: +353-1-4089 800
Telefax: +353-1-4089 830

Italy

GRUNDFOS Pompe Italia
S.r.l.
Tel.: +39-02-95838112
Telefax: +39-02-95309290/
95838461

Japan

GRUNDFOS Pumps K.K.
Phone: +81 53 428 4760
Telefax: +81 53 428 5005

Korea

GRUNDFOS Pumps Korea
Ltd.
Phone: +82-2-5317 600
Telefax: +82-2-5633 725

Latvia

SIA GRUNDFOS Pumps
Latvia
Tāl.: + 371 714 9640, 7 149
641
Fakss: + 371 914 9646

Lithuania

GRUNDFOS Pumps UAB
Tel: + 370 52 395 430
Fax: + 370 52 395 431

Malaysia

GRUNDFOS Pumps Sdn.
Bhd.
Phone: +60-3-5569 2922
Telefax: +60-3-5569 2866

Mexico

Bombas GRUNDFOS de
México S.A. de C.V.
Phone: +52-81-8144 4000
Telefax: +52-81-8144 4010

Netherlands

GRUNDFOS Netherlands
Tel.: +31-88-478 6336
Telefax: +31-88-478 6332 s

New Zealand

GRUNDFOS Pumps NZ Ltd.
Phone: +64-9-415 3240
Telefax: +64-9-415 3250

Norway

GRUNDFOS Pumper A/S
Tlf.: +47-22 90 47 00
Telefax: +47-22 32 21 50

Poland

GRUNDFOS Pompy Sp. z
o.o.
Tel: (+48-61) 650 13 00
Fax: (+48-61) 650 13 50

Portugal

Bombas GRUNDFOS
Portugal, S.A.
Tel.: +351-21-440 76 00
Telefax: +351-21-440 76 90

Romania

GRUNDFOS Pompe
România SRL
Phone: +40 21 200 4100
E-mail:
romania@grundfos.ro

Russia

ООО Грундфос Россия
Тел. (+7) 495 737 30 00,
564 88 00
E-mail
grundfos.moscow@grundfos.
s.com

Serbia

Grundfos Srbija d.o.o.
Phone: +381 11 2258 740
Telefax: +381 11 2281 769

Singapore

GRUNDFOS (Singapore)
Pte. Ltd.
Phone: +65-6681 9688
Telefax: +65-6681 9689

Slovakia

GRUNDFOS s.r.o.
Phona: +421 2 5020 1426

Slovenia

GRUNDFOS LJUBLJANA,
d.o.o.
Phone: +386 (0) 1 568 06
10
Telefax: +386 (0) 1 568 06
19

South Africa

GRUNDFOS (PTY) LTD
Phone: (+27) 11 579 4800
Fax: (+27) 11 455 6066
E-mail:
lsmart@grundfos.com

Spain

Bombas GRUNDFOS
España S.A.
Tel.: +34-91-848 8800
Telefax: +34-91-628 0465

Sweden

GRUNDFOS AB
Tel.: +46(0)771-32 23 00
Telefax: +46(0)31-331 94 60

Switzerland

GRUNDFOS Pumpen AG
Tel.: +41-44-806 8111
Telefax: +41-44-806 8115

Taiwan

GRUNDFOS Pumps
(Taiwan) Ltd.
Phone: +886-4-2305 0868
Telefax: +886-4-2305 0878

Thailand

GRUNDFOS (Thailand) Ltd.
Phone: +66-2-725 8999
Telefax: +66-2-725 8998

Turkey

GRUNDFOS POMPA San.
ve Tic. Ltd. Sti.
Phone: +90 - 262-679 7979
Telefax: +90 - 262-679 7905
E-mail: satis@grundfos.com

Ukraine

Бізнес Центр Європа
Телефон: (+38 044) 237 04
00
Факс.: (+38 044) 237 04 01

United Arab Emirates

GRUNDFOS Gulf
Distribution
Phone: +971-4- 8815 166
Telefax: +971-4-8815 136

United Kingdom

GRUNDFOS Pumps Ltd.
Phone: +44-1525-850000
Telefax: +44-1525-850011

U.S.A.

GRUNDFOS Pumps
Corporation
Phone: +1-913-227-3400
Telefax: +1-913-227-3500

Uzbekistan

Grundfos Tashkent,
Uzbekistan The
Representative Office of
Grundfos Kazakhstan in
Uzbekistan
Телефон: (+998) 71 150
3290 / 71 150 3291
Факс: (+998) 71 150 3292

Addresses revised
05.12.2016

be think innovate

99323167 0817

ECM: 1214346

The name Grundfos, the Grundfos logo, and **be think innovate** are registered trademarks owned by Grundfos Holding A/S or Grundfos A/S, Denmark. All rights reserved worldwide.

© Copyright Grundfos Holding A/S

www.grundfos.com

GRUNDFOS 

Pumpland.ru